

RF transceiver (Zigbee/X-Bee) based energy meter monitoring system. (Energy Meter reading on PC over wireless communication)

The purpose of this project is to read the Energy meter reading and transmit the reading to PC through Zigbee based wireless transmission. This system helps to give a quick reference to the users. This can be achieved by the use of control unit that continuously reads the meter into its permanent (non-volatile) memory location. Then the control unit takes the responsibility to transmit the data and the received data is sent to PC. The final output of this project is going to be the reading of the meter to be displayed on PC wirelessly.

Zigbee is a wireless technology developed as an open global standard to address the unique needs of low-cost, low-power, wireless sensor networks. Zigbee is the set of specs built around the [IEEE 802.15.4](#) wireless protocol. As Zigbee is the upcoming technology in wireless field, we had tried to demonstrate its way of functionality and various aspects like kinds, advantages and disadvantages using a small application of controlling the any kind of electronic devices and machines. The Zigbee technology is broadly adopted for bulk and fast data transmission over a dedicated channel

The control unit which we are making use can also be termed as an onboard computers or microcontrollers. The name onboard computer is given due to the presence of it's built in memory (RAM, ROM) and also due to its input and output ports. The control unit at the energy meter end reads the meter readings and forwards it to the other end using this Zigbee. This information is received by the Zigbee module interfaced to PC and the readings are displayed in the hyper terminal of PC. The Microcontroller used in the project is programmed using Embedded C language.

The major advantage of this system is making use of Zigbee module which helps for a wireless transmission. We can also enjoy the freedom of sharing the same reading with multiple Zigbee ports where we need not require the multiple transmitters.

The main features of this project are:

1. Zigbee based Wireless transmission.
2. Large transmission range.
3. Secured transmission.
4. Dynamic update of meter reading on PC.

The device provides learning's on the following advancements:

1. Zigbee technology.
2. Interfacing Zigbee module to Microcontroller.
3. Interfacing Zigbee module to PC
4. Energy meter interfacing.
5. LCD interfacing with Microcontroller.
6. Embedded C programming.
7. PCB design.

The major building blocks of this project are:

1. Regulated Power Supply.
2. Microcontroller.
3. Zigbee modules.
4. Optocoupler.
5. LCD display with driver.
6. Energy Meter.
7. Reset.
8. Crystal oscillator.
9. LED indicators.

Software's used:

1. PIC-C compiler for Embedded C programming.
2. PIC kit 2 programmer for dumping code into Micro controller.
3. Express SCH for Circuit design.
4. Proteus for hardware simulation.

Regulated Power Supply:

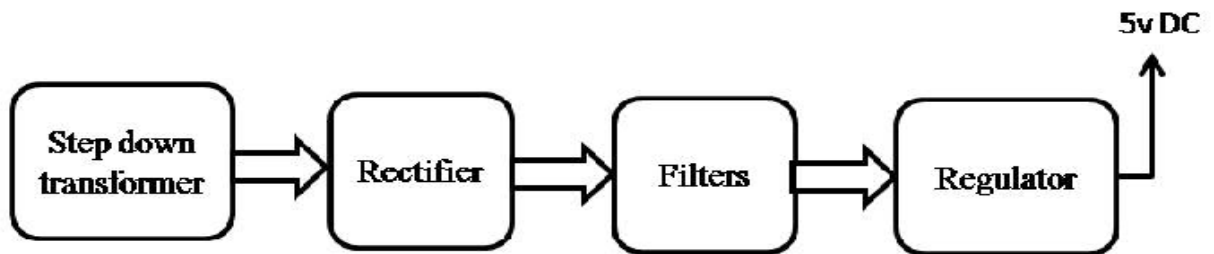

Block Diagram:

RF transceiver (Zigbee/X-Bee) based energy meter monitoring system. (Energy Meter reading on PC over wireless communication)

1. Transmitter

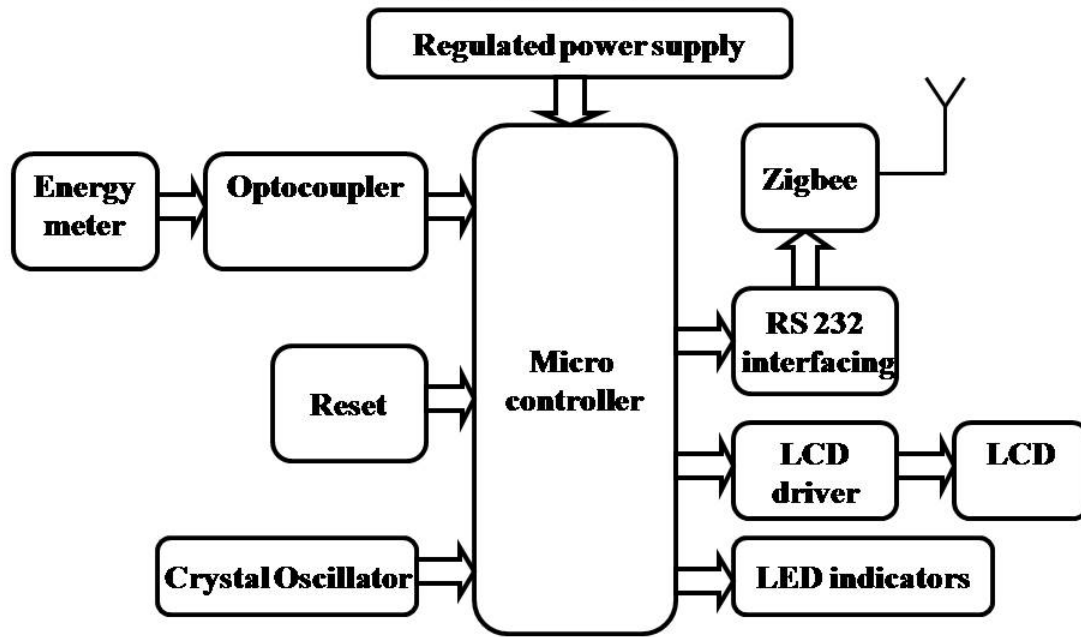

RF transceiver (Zigbee/X-Bee) based energy meter monitoring system. (Energy Meter reading on PC over wireless communication)

2. Receiver

