

Construction of Central Control Unit for Irrigation water pumps. Cost effective method to control entire villager's water pumps with user level authentication. Illiterate's friendly system.

This project aims in providing a user friendly, reliable and automated water pumping system for illiterates. Now a day's technology is running with time, it completely occupied the life style of human beings. Even though there is such an importance for technology in our routine life there are even people whose life styles are very far to this well known term technology. So it is our responsibility to design few reliable systems which can be even efficiently used by them. This basic idea gave birth to the project construction of central control unit for irrigation water pump controller for illiterates and this project aims in introducing the automation technology into the lives of the illiterates.

Automation is the most frequently spelled term in the field of electronics. The hunger for automation brought many revolutions in the existing technologies. One among the technologies which had greater developments is RF communications. The result of this is the RFID cards which transmit a unique identification number. This number transmitted by the RFID can be read with the help of a RF reader.

Here the automation process is done through the wireless RF technology. The RFID reader at the central control unit decodes the RFID tag of that particular user and fed this information as input to the microcontroller unit. The microcontroller transmits the information wirelessly through RF transmitter, to the RF receiver of the users exact water pump connected to the microcontroller. The microcontroller takes the responsibility of controlling the water pump using relay.

In our project we make use of three microcontrollers two are dedicated at the two water pumps and the other with the user at the central control unit. All the

microcontrollers form the heart of the device and there are also two RF receiver modules which are meant for receiving the commands from central control end.

The design of this system is very much sensitive and should be handled with utmost care because the microcontroller is a 5 volts device and it is employed to monitor the house hold power consumption per day where it should be interfaced with a 240 volts energy meter. So every small parameter should be given high importance while designing the interfacing circuit between the controller and the water pump. The major advantage of this device is, it can be operated by the illiterates and the status of the motor can also be known by a simple LED indication more over the device is very economical and can be brought available to the common man.

Features:

1. User friendly interfacing.
2. Controls high voltage water pumps.
3. Identification of water pumps through RFID technology.
4. Wireless control of remote water pump using RF technology.
5. Feedback generated with the help of LED indicator.
6. Highly sensitive.

Applications:

1. Utilized for irrigation purpose.
2. For house hold automations.

This project provides exposure to the following technologies:

1. RFID reader and tags.
2. Interfacing RFID reader and microcontroller.
3. Working of RF transmitter and RF receiver.
4. Embedded C programming for microcontroller.
5. Design of PCB.

The major building blocks of this project are:

1. Regulated power supply.
2. Microcontrollers.
3. Relays with drivers
4. RF transmitter and RF receivers.
5. LCD with driver.
6. Control buttons.
7. Crystal oscillator.
8. Reset
9. LED indicators

Software's used:

1. PIC-C compiler for Embedded C programming.
2. PIC kit 2 programmer for dumping code into Micro controller.
3. Express SCH for Circuit design.
4. Proteus for hardware simulation.

Regulated power supply:

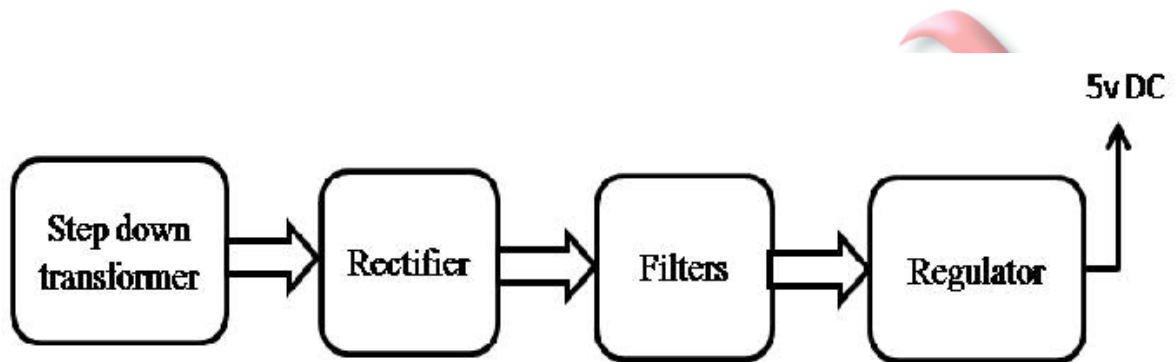

Block diagrams:

Construction of central control unit for Irrigation water pumps

1. At Central unit

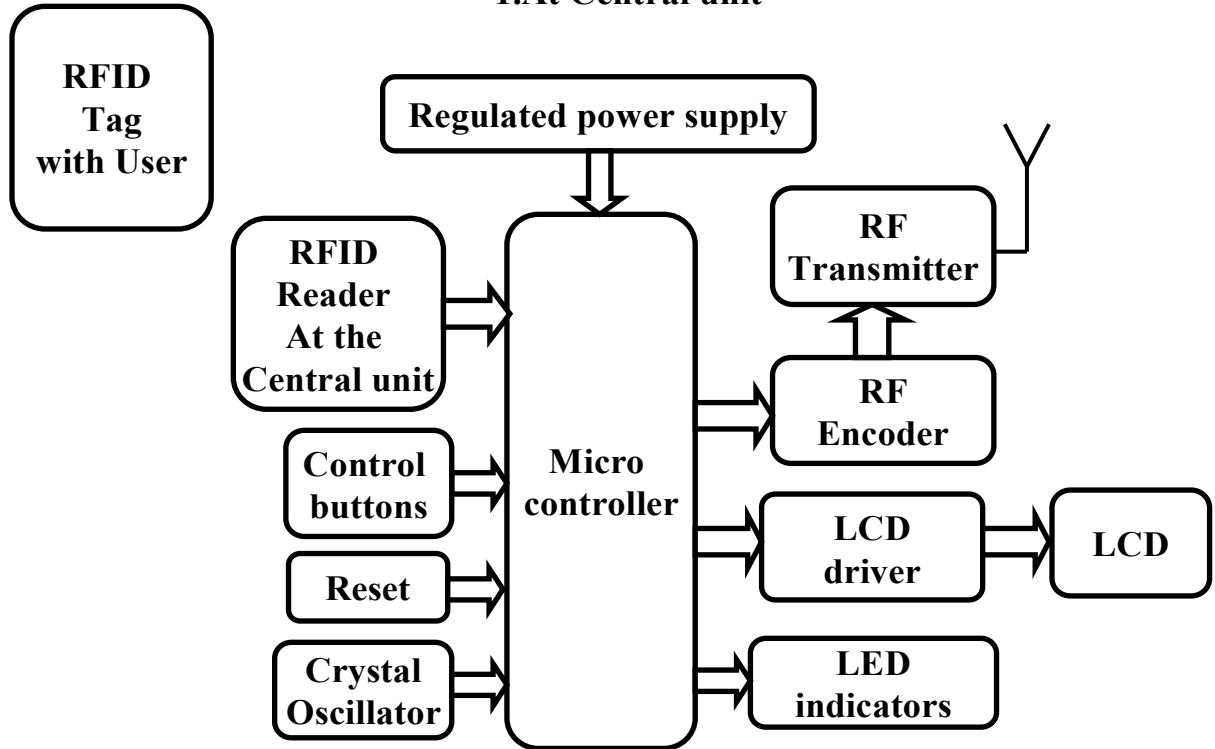

**Construction of central control unit for Irrigation water pumps
2.At Water pump-1**

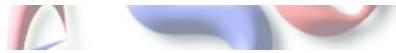
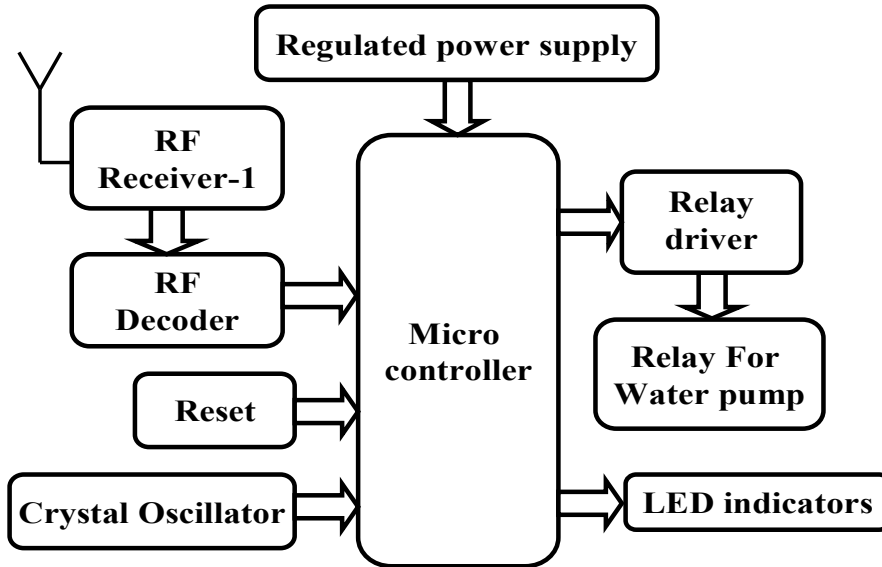

**Construction of central control unit for Irrigation water pumps
2.At Water pump-2**

